

Montageanleitung

Beschlag für Möbelfronten parallel zur Schiebachse gestapelt.

Instructions de montage

Ferrures pour portes de meubles, avec rangement parallèle à l'axe de coulissement.

Installation instructions

Hardware system for cabinet sliding doors that are stacking parallel to the sliding axis.

Istruzioni di montaggio

Ferramenta per parti frontali dei mobili accatastati parallelamente all'asse di spostamento.

Instrucciones de montaje

Herraje para frentes de muebles, estacionamiento paralelo al eje de deslizamiento.

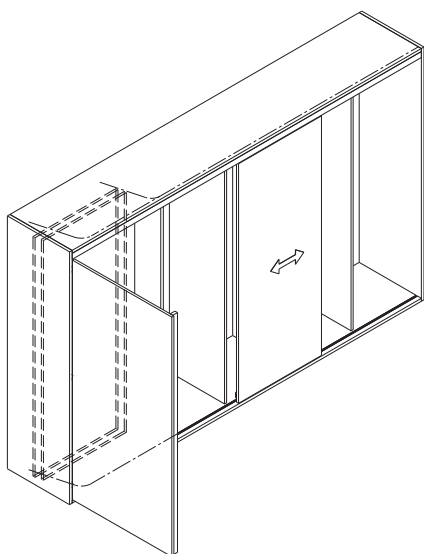

■ Hawa-Teile ■ Eléments Hawa ■ Hawa components ■ Componenti Hawa ■ Componentes Hawa

NOTICE: Metric dimensions are valid – dimensions stated in inches are for information only.

Diese Zeichnung ist Eigentum der Hawa AG und darf weder verwertet, vervielfältigt noch Dritten zugänglich gemacht werden. Alle unsere Katalog-Zeichnungen sowie die speziellen Einbauezeichnungen im Massstab 1:1 usw. stellen Beispiele zum Einbau unserer Beschläge dar. Irgendwelche Ansprüche aus der Verwendung dieser Unterlagen können durch den Kunden nicht abgeleitet werden. Für bau-/projektbezogene, konstruktive Details wird keine Verantwortung übernommen.

Ce plan est la propriété de Hawa AG. Il ne peut être utilisé à titre lucratif, ni photocopié ou transmis à un tiers. Tous les plans publiés dans les catalogues, les plans de montage spéciaux à l'échelle 1:1 etc. représentent des exemples de montage de nos ferrures. Le client ne peut tirer des droits quelconques en utilisant de tels documents. Pour des détails constructifs touchant aux projets ou aux sites, toute responsabilité est déclinée.

This drawing remains the property of Hawa AG and may not be sold, reproduced or made available to third parties. All of our catalogue drawings and special scale installation drawings etc. represent installations using our hardware and fittings. No claims on the part of the customers can be considered which arise in connection with the use of these documents. For site or project-related design details any liability is declined.

Questo disegno è proprietà di Hawa AG e non può essere usato a scopo di lucro, riprodotto e reso accessibile a terzi. Tutti i nostri disegni del catalogo nonché i particolari disegni di montaggio in scala 1:1 ecc. rappresentano esempi per il montaggio delle nostre ferramenta. Eventuali rivendicazioni a seguito dell'utilizzo di questa documentazione non possono essere evidenziate da parte del cliente. Non assumiamo nessuna responsabilità per dettagli costruttivi che riguardano qualsiasi costruzioni o progetti.

Este documento es propiedad de la empresa Hawa AG. Se excluye la venta y reproducción, al igual que el acceso a terceras personas. Los planos contenidos en nuestros catálogos, al igual que los planos especiales de montaje a escala 1:1 etc. representan ejemplos para el montaje de nuestros herrajes. Su uso no implica la deducción de derechos, cualquiera sea su naturaleza, por parte del cliente. No asumimos ninguna responsabilidad por los detalles constructivos relativos a la construcción o proyectos.

-	Gezeichnet/Dessiné/Drafted/Disegnato/Dibujado 09.00 / STJ	Internationale Schutzrechte Änderungen vorbehalten Droits internationaux déposés Sous réserve de modifications Swiss and foreign patents Design subject to modification Diritti protettivi internazionali Con riserva di apportare modifiche Derechos internacionales protegidos Planos sujetos a modificaciones
	Änderung/Modification/Modification/Modifica/Modificación 04.2012 / RHU	
17808	Ersetzt/Remplace/Replaces/Sostituisce/Reemplaza 17808a	
	Visum/Visa/Visa/Visado 05.2012 / FÜG	
b		

Deutsch

HAWA-Aperto 40/F

Maximales Türgewicht 40 kg
Maximale Türhöhe 2600 mm
Minimale Türbreite 400 mm
Maximale Türbreite 900 mm
Türdicke 19 mm – 25 mm
Dicke von Boden und Deckel min. 25 mm

Ausrichtbeschlag empfohlen.

Français

HAWA-Aperto 40/F

Poids maximum par porte 40 kg
Hauteur maximum par porte 2600 mm
Largeur minimum par porte 400 mm
Largeur maximum par porte 900 mm
Epaisseur de porte 19 mm – 25 mm
Epaisseur minimum des panneaux haut et bas 25 mm

Nous recommandons d'utiliser une ferrure d'alignement.

English

HAWA-Aperto 40/F

Maximum panel weight 40 kg (88 lbs.)
Maximum panel height 2600 mm (8'6 $\frac{3}{8}$ ")
Minimum panel width 400 mm (1'3 $\frac{3}{4}$ ")
Maximum panel width 900 mm (2'11 $\frac{7}{16}$ ")
Panel thickness 19 mm – 25 mm ($\frac{3}{4}$ " – $\frac{31}{32}$ ")
Thickness of furniture top and bottom at least 25 mm ($\frac{31}{32}$ ")

It is recommended to use a door straightening system.

Italiano

HAWA-Aperto 40/F

Peso massimo della porta 40 kg
Altezza massima della porta 2600 mm
Larghezza minima della porta 400 mm
Larghezza massima della porta 900 mm
Spessore della porta 19 mm – 25 mm
Spessore del fondo e del coperchio min. 25 mm

Si consiglia l'uso di ferramenta di allineamento.

Español

HAWA-Aperto 40/F

Peso máximo de puerta 40 kg
Altura máxima de puerta 2600 mm
Ancho mínimo de puerta 400 mm
Ancho máximo de puerta 900 mm
Espesores de puerta 19 a 25 mm
Espesor mínimo del suelo y tapa 25 mm

Se recomienda herraje de alineación.

Komponenten
Composants
Components
Componenti
Componentes

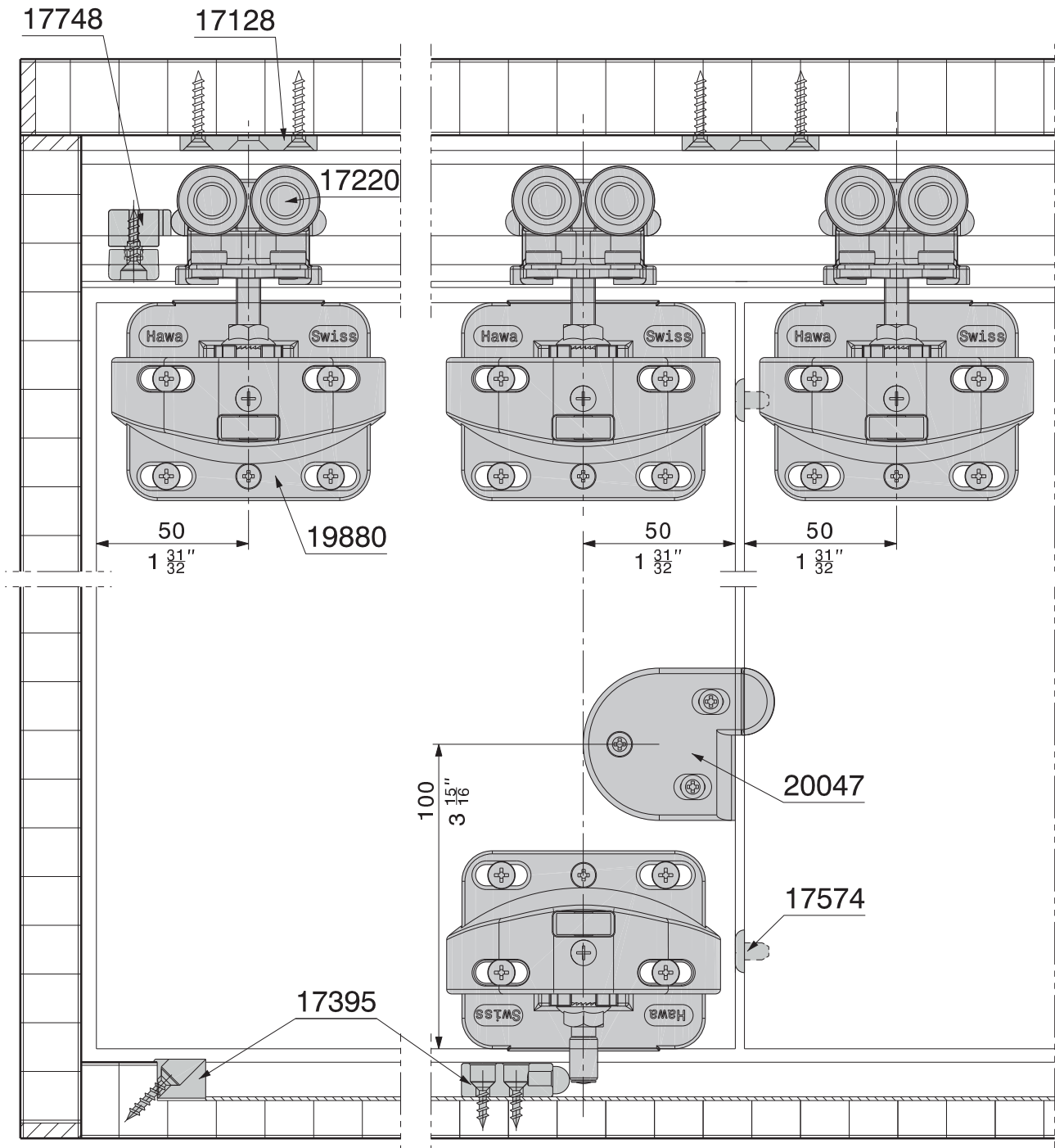

Technische Änderungen vorbehalten
 Sous réserve de modifications techniques
 Subject to modification

Con riserva di apportare modifiche tecniche
 Bajo reserva de modificaciones técnicas

Mittelwand / Drehtüre
Cloison centrale / porte pivotante
Centre wall / pivot door
Parete centrale / porta girevole
Pared mediana / puerta giratoria

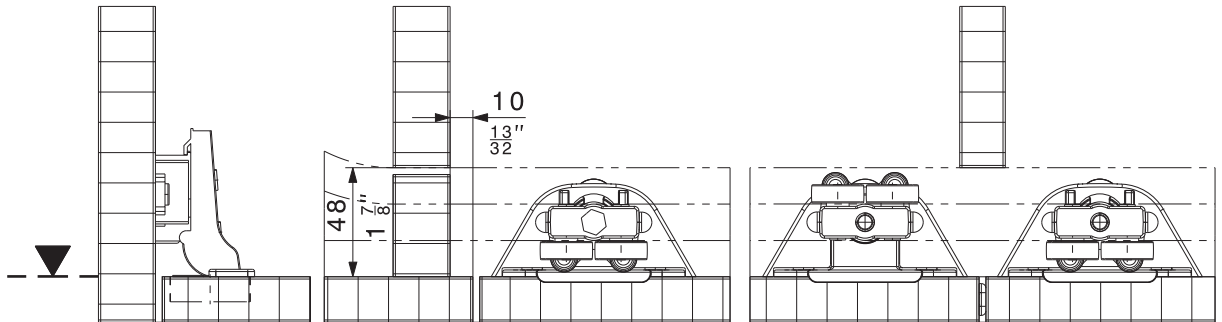

Innenseite Türe = Vorderkante Laufschiene
Côté intérieur porte = bord avant rail de roulement
Inside face of door = front edge of top track
Lato interno della porta = bordo anteriore della rotaia
Lado interno de la puerta = Canto anterior riel de rodamiento

▼
Vorderkante Laufschiene
Bord avant rail de roulement
Front edge of top track
Bordo anteriore della rotaia
Canto anterior riel de rodamiento

Technische Änderungen vorbehalten
Sous réserve de modifications techniques
Subject to modification

Con riserva di apportare modifiche tecniche
Bajo reserva de modificaciones técnicas

Distanzen
Distances
Distances
Distanze
Distancias

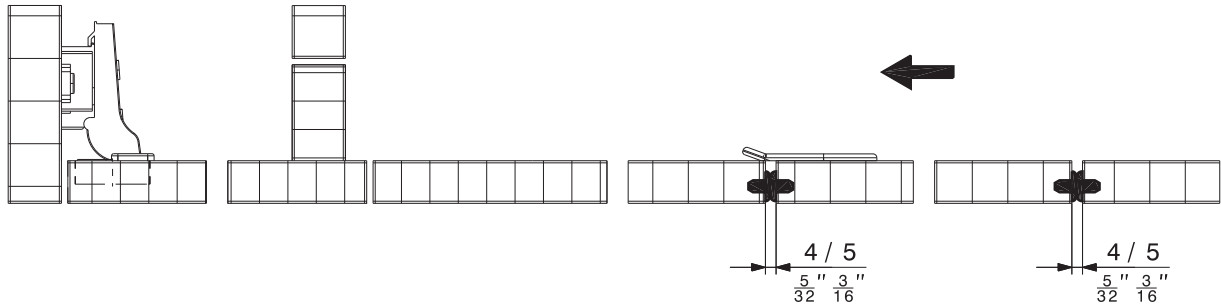
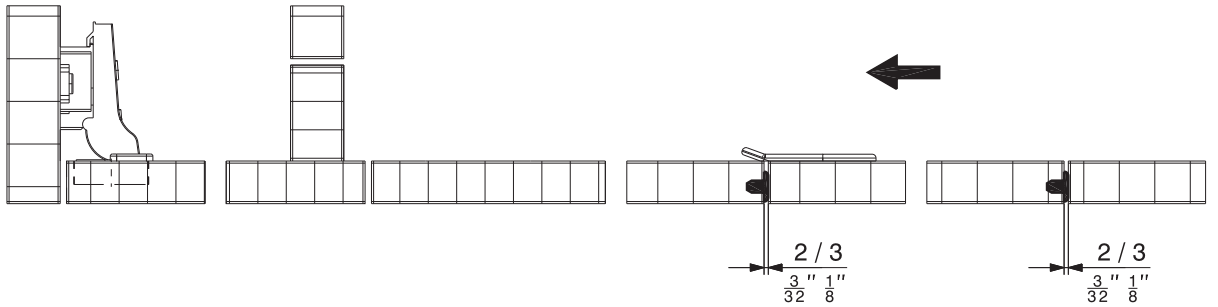

Schloss
Serrure
Lock
Serratura
Cerradura

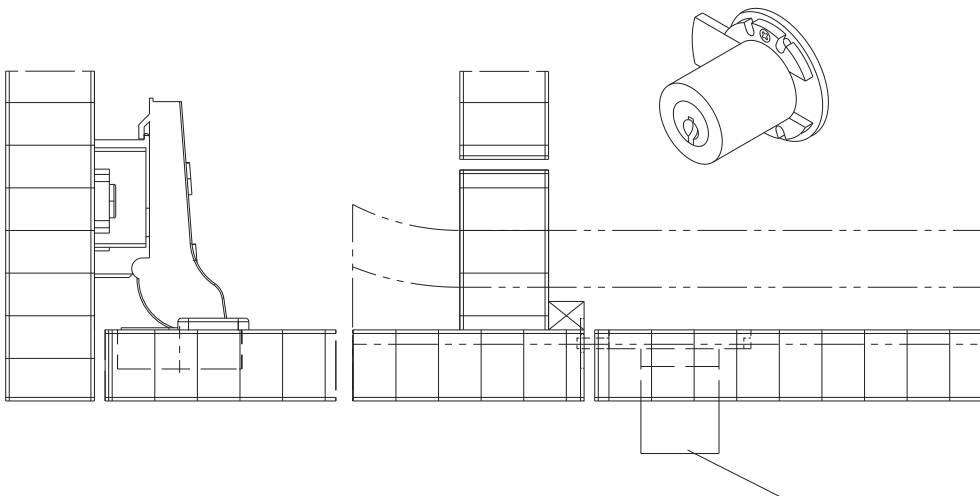

Schloss bauseits
 Serrure incombant au client
 Lock provided by customer
 Serratura del committente
 Cerradura per parte del contratista

Anlage mit zwei Stapelräumen
Installation avec deux espaces de parcage
System featuring two stacking areas
Impianto con due vani di parcheggio
Instalación con dos recintos de apilado

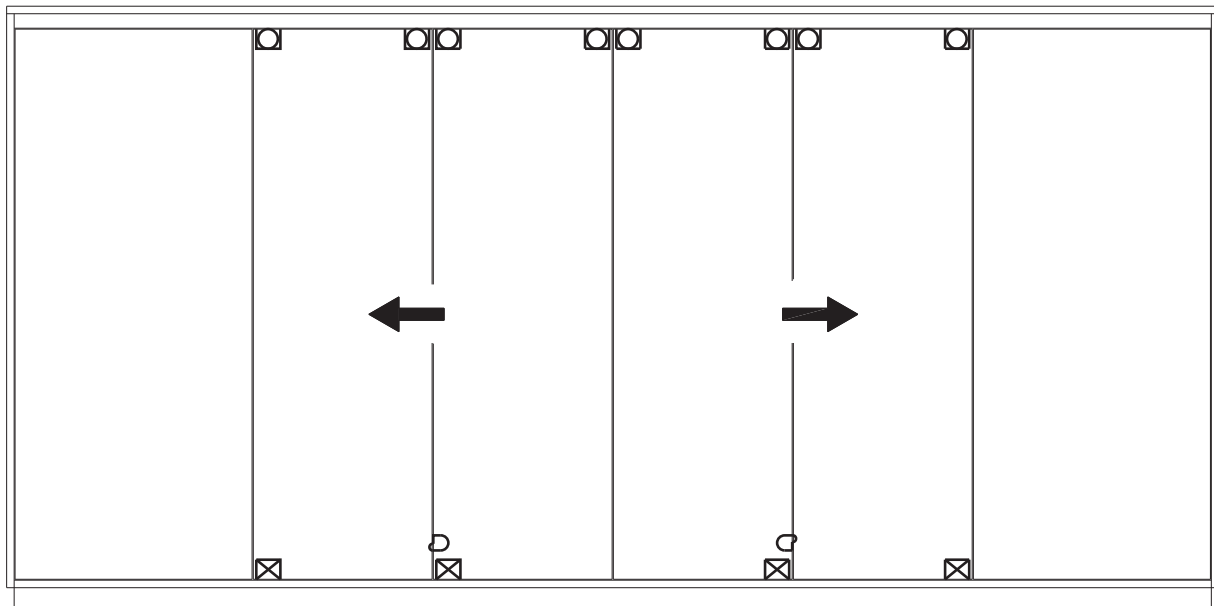

☒ Position Bodenführung
 Position guide du bas
 Position of bottom guide
 Posizione guida pavimento
 Posición guía en el suelo

ⓐ Position Türbündighalter
 Position dispositif d'affleurement des portes
 Position of panel surface equalizer
 Posizione dispositivo de tenuta a filo delle ante
 Posición pieza para mantener des batientes a nivel

ⓐ Position Aufhängung
 Position suspension
 Position of suspension facility
 Posizione sospensione
 Posición suspensión

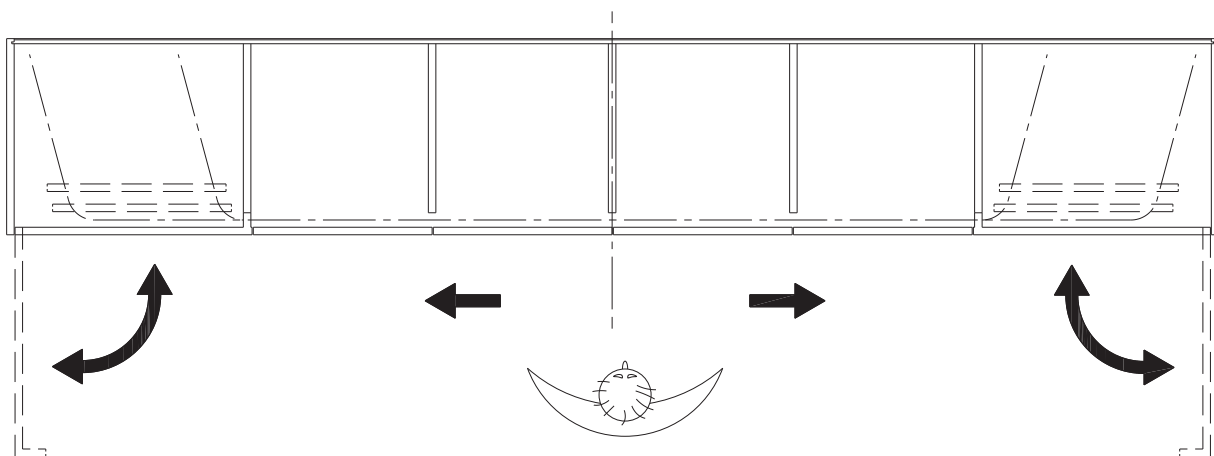

Anlagen mit zwei Stapelräumen gelten als zwei Anlagen.
 Systèmes avec deux espaces de parcage sont considérés comme deux installations.
 Installations with two stacking areas are considered as two systems.
 Gli impianti con due vani di parcheggio sono considerati come due impianti.
 Las instalaciones con dos recintos de apilado se consideran como dos instalaciones.

Technische Änderungen vorbehalten
 Sous réserve de modifications techniques
 Subject to modification

Con riserva di apportare modifiche tecniche
 Bajo reserva de modificaciones técnicas

*Berechnung ab Lichtmassbreite
Calculs à partir de la largeur intérieure
Calculations as from the inside width
Calcolo a partire dalla larghezza interna
Cálculo a partir del ancho de luz*

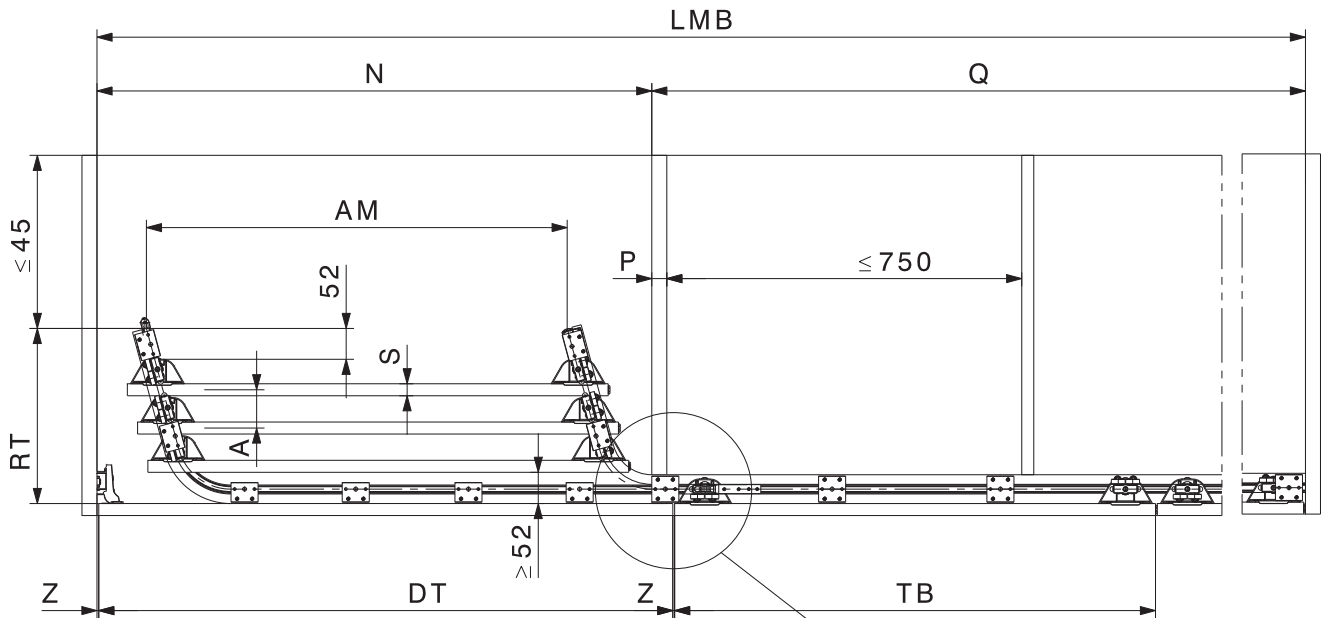

AM =	Achsabstand Ecartement d'axe Axis-centre distance Interasse Distancia entre ejes
AT =	Anzahl Schiebetüren TB Nombre de portes coulissantes TB Number of sliding panels TB Numero porte scorrevoli TB Número de puertas deslizantes TB
DT =	Drehtüre Porte pivotante Pivot door Porta girevole Puerta pivotante
LMB =	Lichtmassbreite Largeur intérieure Inside width Larghezza interna Ancho de luz
M =	Variable Variable Variable Variable Variable
N =	Variable Variable Variable Variable Variable

P =	Mittelwanddicke Epaisseur de la cloison centrale Centre wall thickness Spessore della parete centrale Espesor de la pared medianera
Q =	Variable Variable Variable Variable Variable
RT =	Stapelraumtiefe Profondeur de l'espace de parcage Stacking area depth Profondità zona di impacchettamento Profundidad de la zona de apilado
S =	Türdicke Epaisseur de la porte Door thickness Spessore della porta Espesor de puerta
TB =	Türbreite Largeur par porte Panel width Larghezza della porta Ancho de puerta
Z =	Fugenbreite Espace entre les portes Gap width Intercapedine Espacio intermedio entre puertas

S =	
Z =	
P =	
LMB =	
AT =	

$A = S + 43$	
$RT = AT \times A + 104$	
$M = AT \times 20 + 50 + P$	
$TB = \frac{LMB - M - Z}{AT + 1} - Z$	
$AM = TB - 100$	
$DT = TB + M$	
$N = DT - 10 - P + Z$	
$Q = LMB - N$	

Berechnungen ab Mass Q oder Türbreite
Calculs à partir de la cote Q ou de la largeur de porte
Calculations based on dimension Q or panel width
Calcoli a partire dalla misura Q o dalla larghezza della porta
Cálculo a partir de la dimensión Q o del ancho de puerta

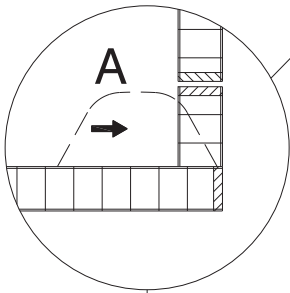
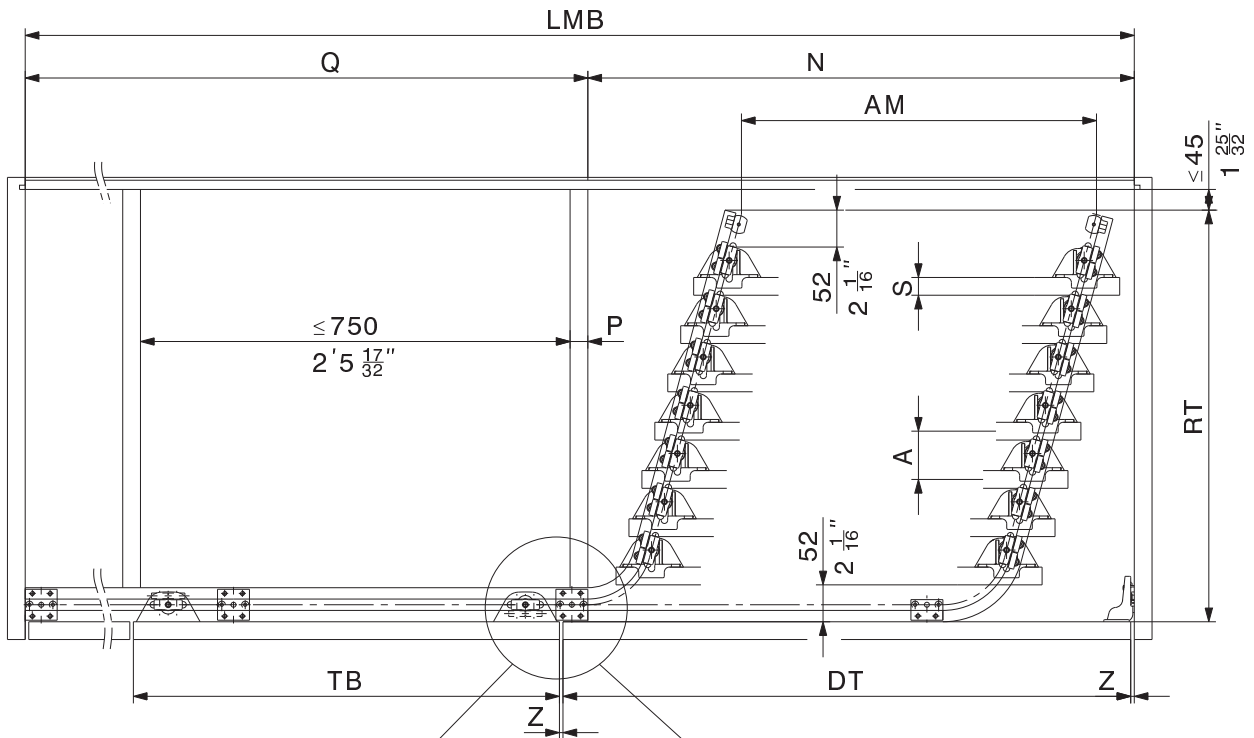

S =	
Z =	
P =	
Q =	
TB =	
AT =	

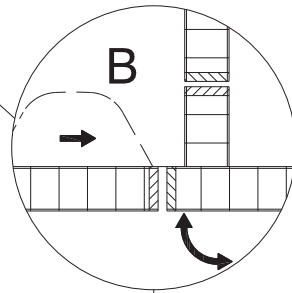

A		B
	$A = S + 43$	
	$RT = AT \times A + 104$	
	$TB = \frac{Q}{AT} - Z$	
	$TB = \frac{Q - P - 10 - Z}{AT} - Z$	
	$AM = TB - 100$	
	$Q = (TB + Z) \times AT$	
	$Q = (TB + Z) \times AT + P + Z + 10$	
	$N = AT \times 20 + 40 + TB + Z$	
	$LMB = Q + N$	
	$DT = N + P + 10 - Z$	

Berechnungen der Schienen
Calculs des rails
Track calculations

Calcoli delle rotaie
Cálculo de los rieles

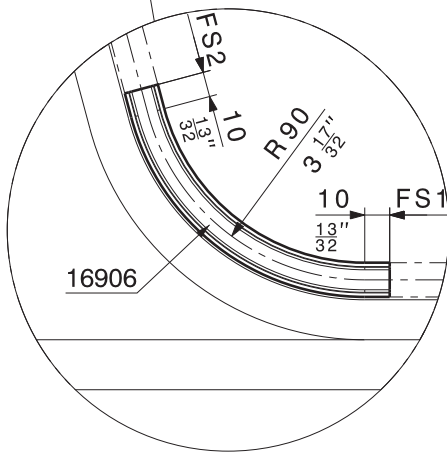
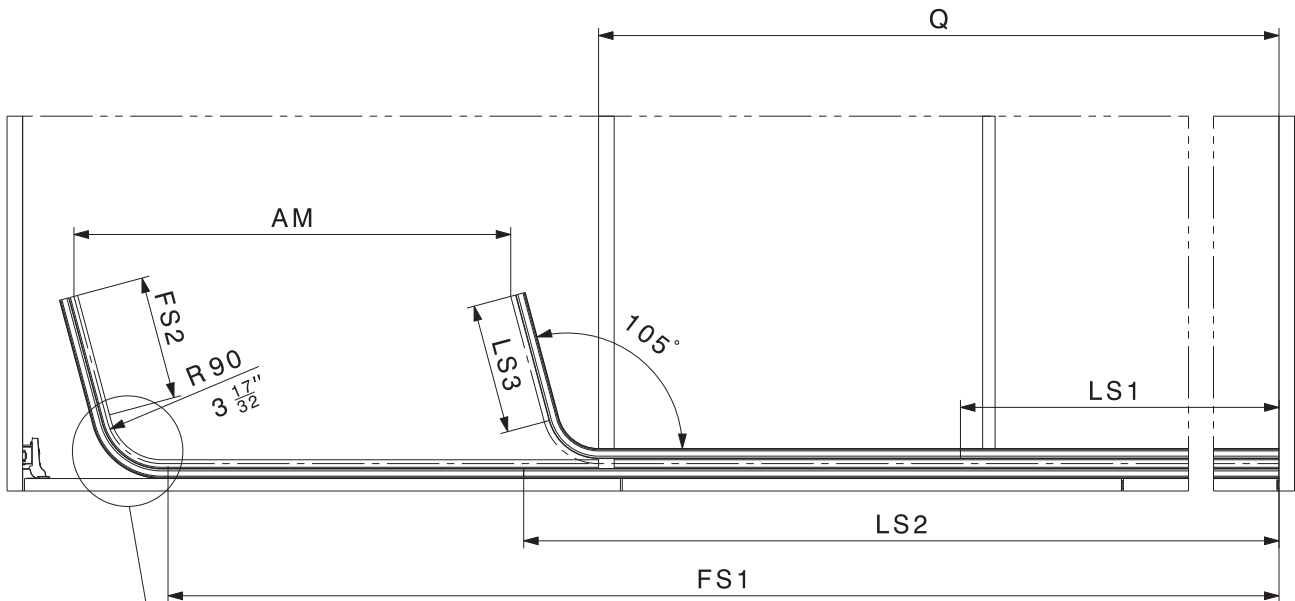

$LS1 = Q - 580$	
$LS2 = Q - 580 + AM$	
$LS3 = (RT - 97) \times 1.035$	
$FS1 = Q + AM - 10$	
$FS2 = LS3 - 10$	

LS =	Laufschiene Rail de roulement Top track Rotaia Riel de rodamiento
FS =	Führungsschiene Rail de guidage Bottom guide channel Guida Riel de guía

Aufhängelaschen
Platines de suspension
Top fixing plates
Piastrine di sospensione
Bridas de suspensión

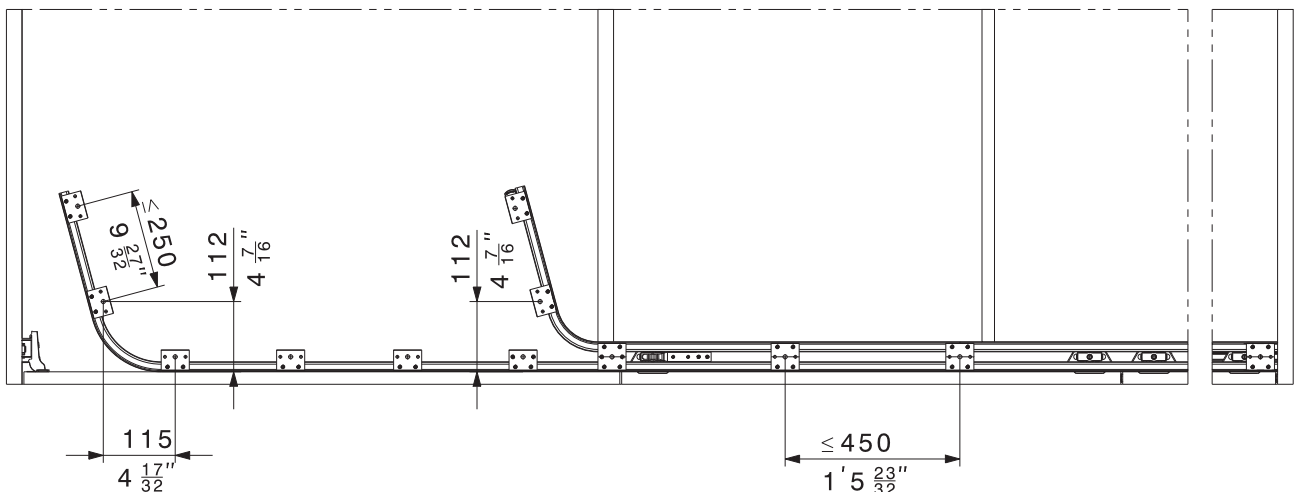

Bearbeitungsmasse
 Cotes de façonnage
 Drilling and recessing dimensions
 Dimensioni di lavorazione
 Dimensiones de mecanizado

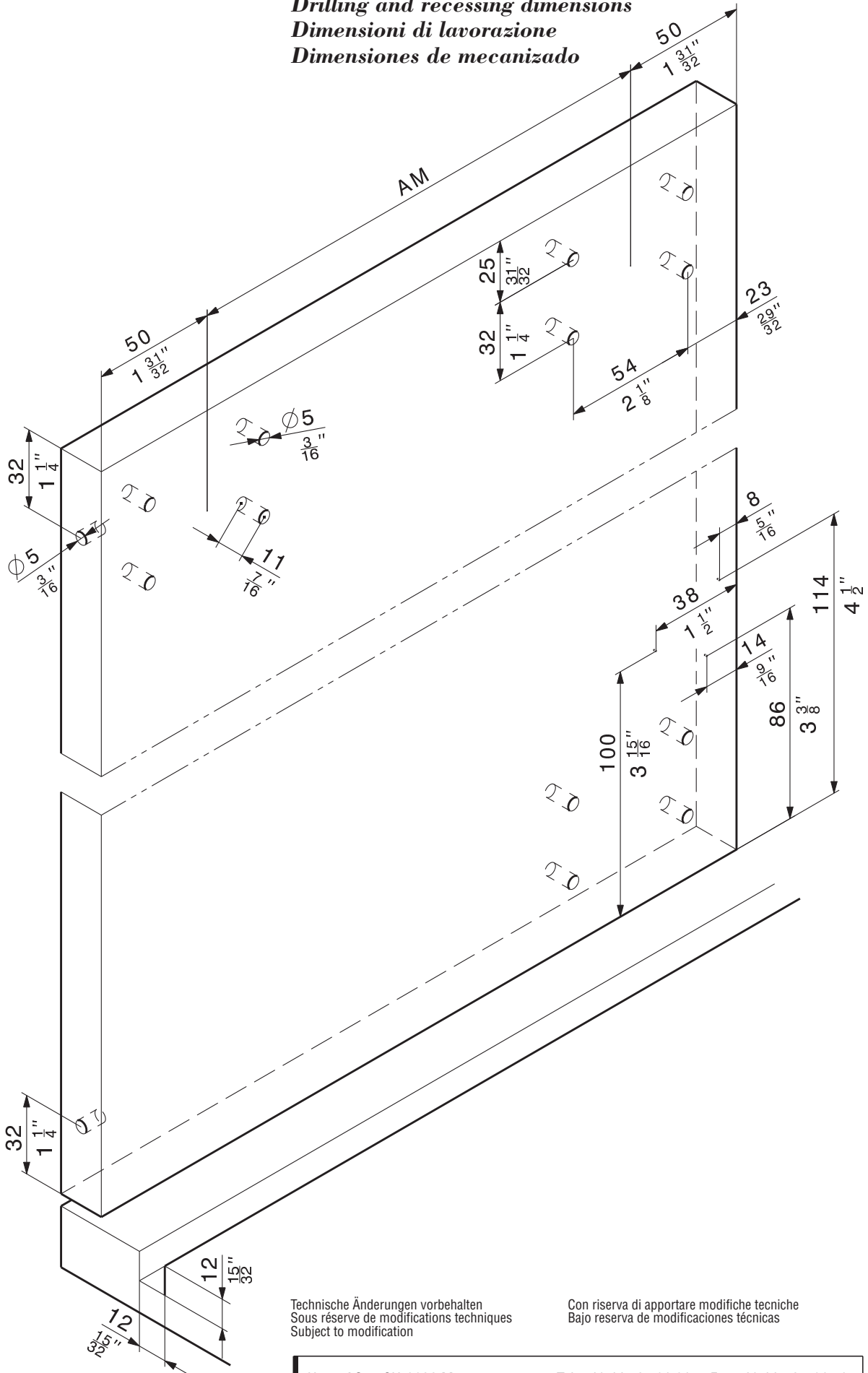

Technische Änderungen vorbehalten
 Sous réserve de modifications techniques
 Subject to modification

Con riserva di apportare modifiche tecniche
 Bajo reserva de modificaciones técnicas

*Montage der Führungsschienen
Montage des rail de guidage
Mounting of bottom guide channels
Montaggio delle guide
Montaje de los rieles de guía*

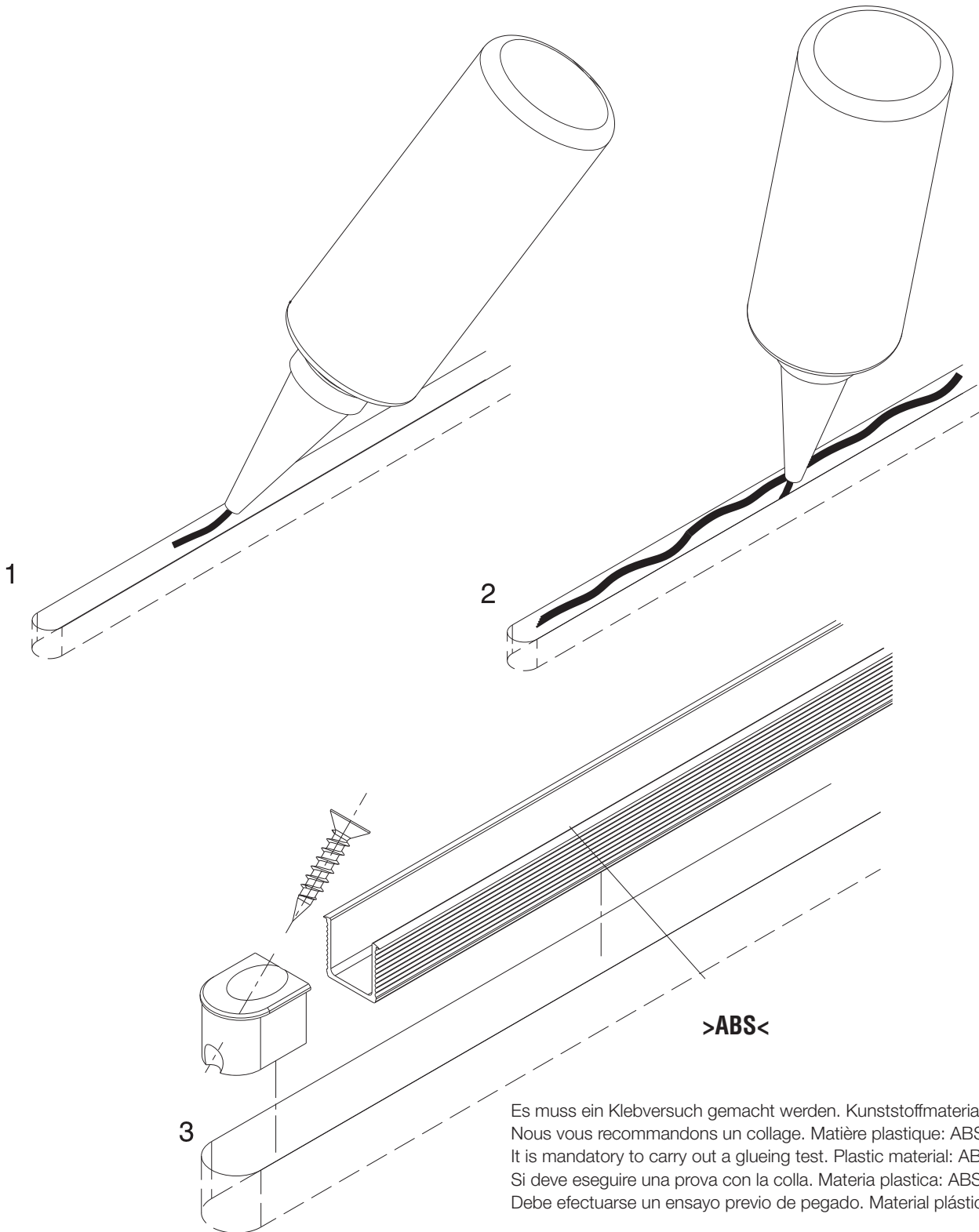

Technische Änderungen vorbehalten
Sous réserve de modifications techniques
Subject to modification

Con riserva di apportare modifiche tecniche
Bajo reserva de modificaciones técnicas

Montage der Laufschienen
Montage des rails de roulement
Mounting of top tracks
Montaggio delle rotaie
Montaje de los rieles de rodamiento

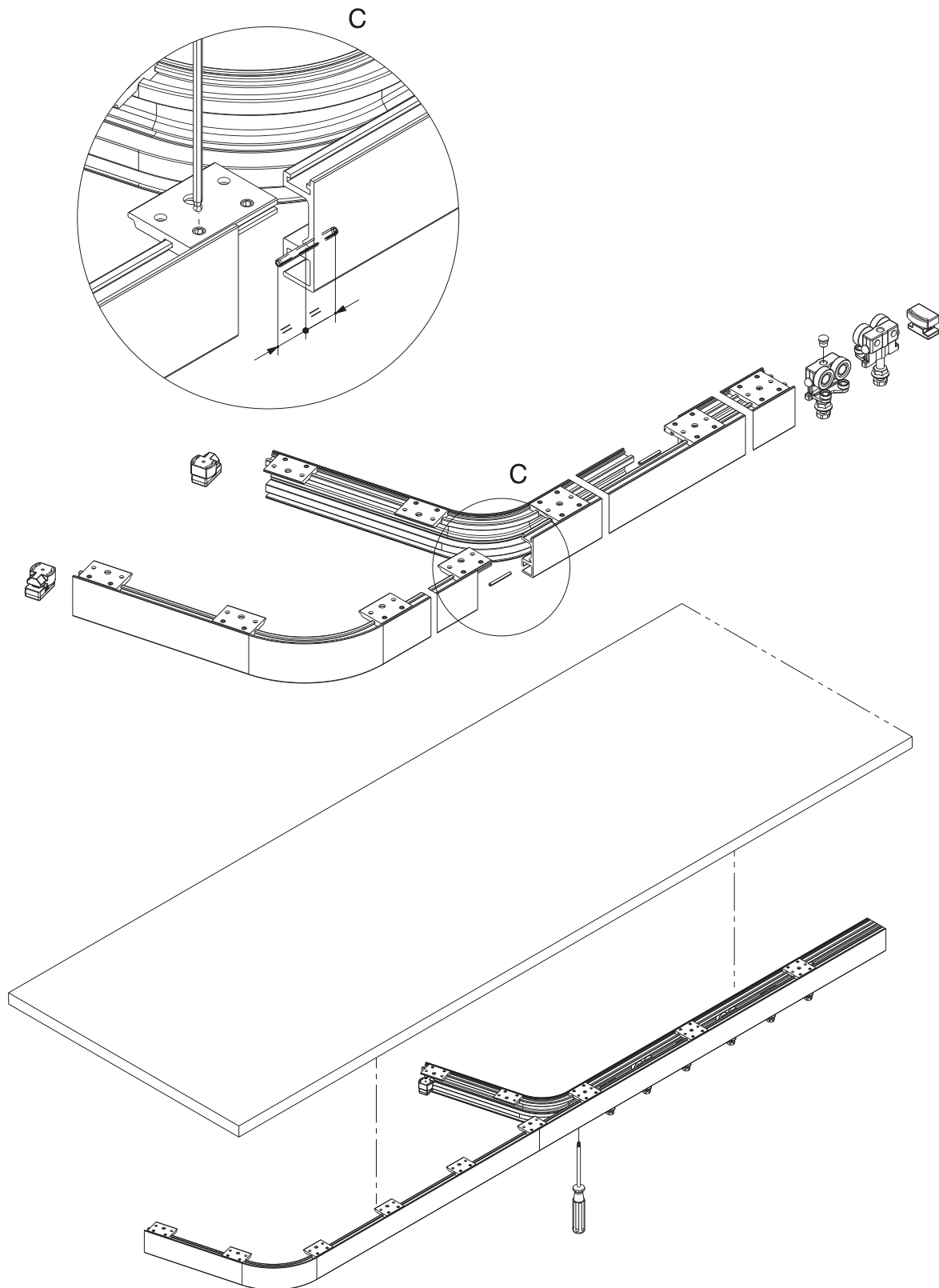

Technische Änderungen vorbehalten
Sous réserve de modifications techniques
Subject to modification

Con riserva di apportare modifiche tecniche
Bajo reserva de modificaciones técnicas

Montage der Schiebetüre
Montage de la porte coulissante
Mounting of sliding door
Montaggio della porta scorrevole
Montaje de la puerta deslizando

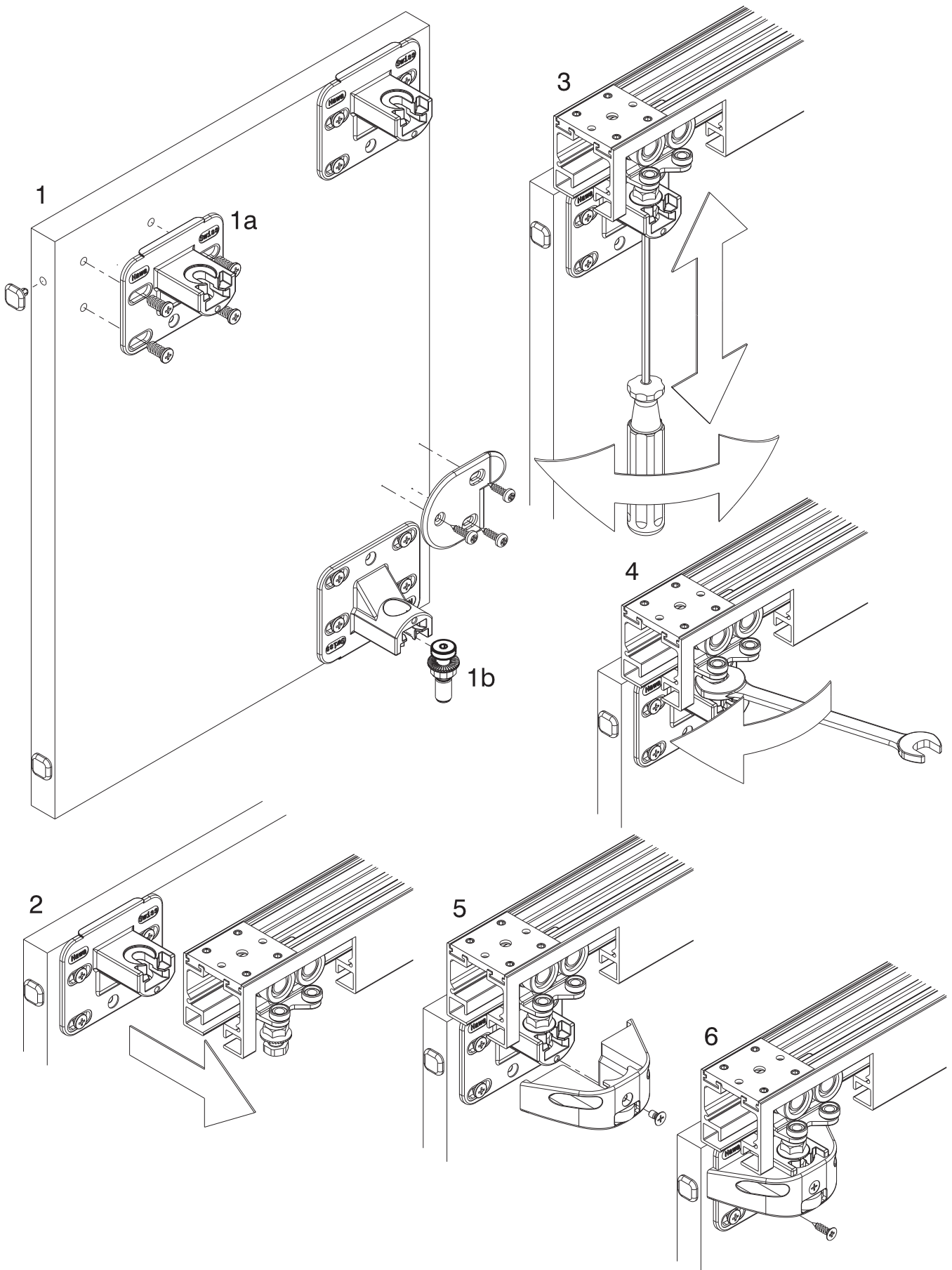

Mittelpuffer
Butée médiane
Centre stop
Paracolpi centrale
Amortiguador mediano

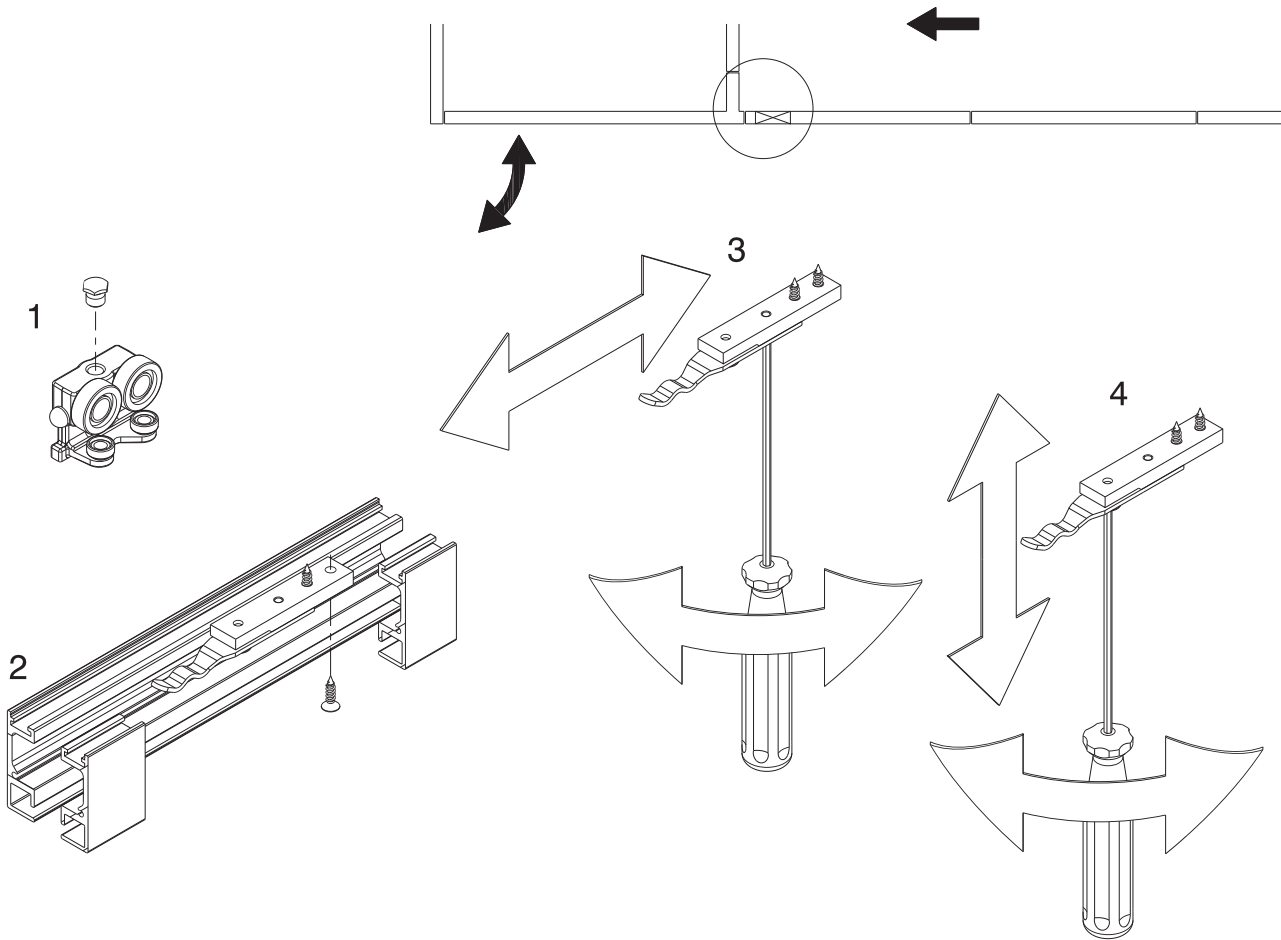



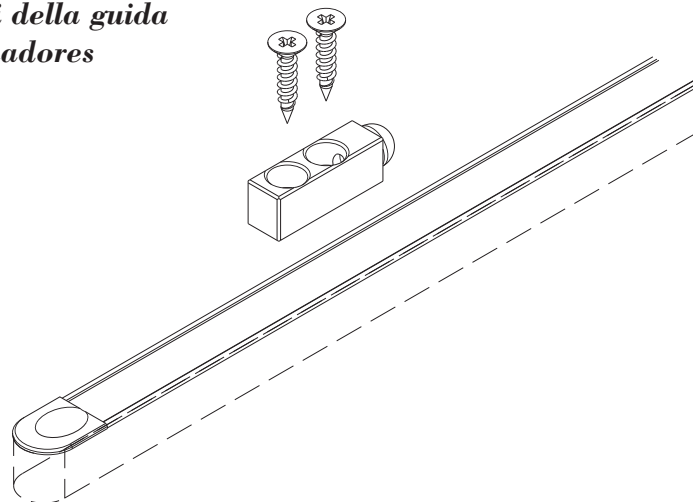







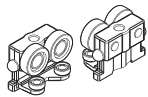



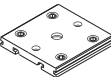
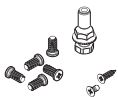
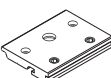

Montage Führungsschiennenpuffer
Montage de la butée du rail de guidage
Mounting of bottom guide bumper
Montaggio del paracolpi della guida
Montaje de los amortiguadores de los rieles de guía



Technische Änderungen vorbehalten
Sous réserve de modifications techniques
Subject to modification

Con riserva di apportare modifiche tecniche
Bajo reserva de modificaciones técnicas

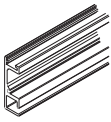
Beschlägeübersicht
Composants de la ferrure
Hardware system components
Assortimento ferramenta
Componentes de los herrajes

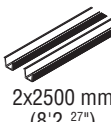
	Laufwerk 2-rollig M8, Set à 2 Stück Chariot à 2 galets M8, jeu à 2 pièces Two-wheeled trolley M8, set of 2 pieces Carrello a 2 rulli M8, set da 2 pezzi Carro de dos rodillos M8, juego de 2 piezas	17220		Einfachlaufschiene-Bogen 75°, aussen Simple rail de roulement, segment courbé, 75° à l'extérieur, Single top track curved segment 75°, outside Rotaia curva semplice 75°, esterna Segmento de riel de rodamiento simple, curvado hacia el exterior 75°	17290
	Laufwerk 2-rollig M8, 1 Stück Chariot à 2 galets M8, 1 pièce Two-wheeled trolley M8, 1 piece Carrello a 2 rulli M8, 1 pezzo Carro de dos rodillos M8, 1 piezas	17927		Führungsschiene-Bogen 75° Rail de guidage, segment courbé 75° Curved bottom guide channel 75° Guida curva 75° Segmento de riel de guía curvado 75°	16906
	Aufhänge- und Montageschrauben Vis de réglage, et de fixation de la cuirasse Suspension bolts and mounting screws Viti di sospensione e di montaggio Tornillos de suspensión y montaje	19958		Aufhängelasche zu 2x Einfachlaufschiene Platine de suspension pour 2x simple rail de roulement Top fixing plate for 2x single top track Piastrina di sospensione per 2x rotaia semplice Brida de suspensión para 2x riel simple	17128
	Führungszapfen- und Montageschrauben Goujon de guidage, et vis de fixation de la cuirasse Guide pin and mounting screws Viti dei perni di guida e di montaggio Tornillos de montaje y pernos de guía	19959		Aufhängelasche zu Einfachlaufschiene Platine de suspension pour simple rail de roulement Top fixing plate for single top track Piastrina di sospensione per rotaia semplice Brida de suspensión para riel simple	17749
	Türenbündighalter Dispositif d'affleurement des portes Panel surface equalizer Dispositivo de tenuta a filo delle ante Pieza para mantener deos batientes a nivel	20047		Laufschiennenverbindungsstifte Goujons de raccordement p. rails de roulem. Top track connecting bolts Spine di collegamento delle rotaie Espigas de unión para rieles de rodamiento	17221
	Befestigungstopf D=40 mm Cuirasse de fixation D=40 mm Fixing cup D=40 mm Tazza di fissaggio D=40 mm Armadura de fijación D = 40 mm	19880		Laufschiennen-Endpuffer Butées de fin de course pour rails de roulem. Top track end stops Paracolpi per le rotaie Amortiguadores finales	17748
	Abdeckkappen, KS schwarz, zu 17174 Cache, plastique noir, pour 17174 Cover cap, plastic black, for 17174 Copriforo, plastica nera, per 17174 Tapa, plástico negro, para 17174	17678		Puffer/Endstück, KS schwarz Butées de fin de course, plastique noir Bumpers/end stoppers, plastic black Paracolpi/elemento finale, plastica nera Amortiguadores/pieza final, plástico negro	17395
	Distanzen für Türfuge 2 mm Pièces d'écartement pour jeu de porte 2 mm Spacers for panel clearance of 2 mm, Distanze per aria della porta 2 mm Piezas distanciadoras para juego de puerta de 2 mm	17574		Mittelpuffer mit einstellbarer Rückhalterung Butée médiane à blocage réglable Centre stop with progressively adjustable retention spring catch Paracolpi centrale con arresto regolabile Amortiguador mediano con retención	17283
	Distanzen für Türfuge 3 mm Pièces d'écartement pour jeu de porte 3 mm Spacers for panel clearance of 3 mm, Distanze per aria della porta 3 mm Piezas distanciadoras para juego de puerta de 3 mm	17929		Einfachlaufschiene, Leichtmetall farblos eloxiert Simple rail de roulement, métal léger, anodisé incolore Single top track, alu plain anodized Rotaia semplice, metallo leggero anodizzata incolore Riel de rodamiento simple, metal ligero anodizado incoloro	2500 mm (8'2 $\frac{7}{16}$) 3500 mm (11'5 $\frac{13}{16}$) 17795 17796
	Einfachlaufschiene-Bogen 75°, innen Simple rail de roulement, segment courbé, 75° à l'intérieur, Single top track curved segment 75°, inside Rotaia curva semplice 75°, interna Segmento de riel de rodamiento simple, curvado hacia el interior 75°	17289		Führungsschiene, KS schwarz Rail de guidage, plastique noir Bottom guide channel, plastic black Guida, plastica nera Riel de guía, plástico negro	17066